



Rotary Clothesline

37 and 47

Product Manual



Congratulations

Congratulations on the purchase of your **Sun King Rotary Clothesline**, which will bring you many years of trouble free and efficient drying.

It's important that you read this Product Manual thoroughly before installation to benefit from the design features and enjoy safe use of this product.

Thank you for choosing Sun King.

Patents and Registered Designs apply to this product.

Warning

- Do not allow children or pets to swing on the clothesline or items of laundry.
- Ensure when raising and lowering your clothesline that bystanders (in particular children) are standing well clear.
- Do not use for any purpose other than to hang and dry washing.
- Do not use your clothesline if parts are worn or damaged.
- Do not allow the frame to lower in an uncontrolled manner as damage or injury may result.

Carton Contents

Please retain this Product Manual. Record the following information for future reference.

Product Number (printed on carton): _____

Date of purchase: _____

Name and location of store: _____

Part name	Qty.
Main standard	1
Head assembly	1
Ground socket with cover	1
Plastic spacers	3

Step 1 – Select a suitable location

- 1.1 Select a suitable area for installation.
- 1.2 Allow a minimum of 500mm clearance around your Rotary Hoist (**Fig. 1**).

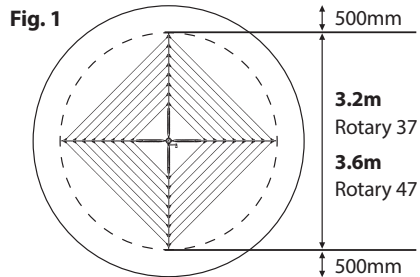

Designed and tested under a Quality System that meets Hills demanding quality specifications.

Made in China

Step 2 – Install the Ground Socket

- 2.1 Dig a hole 250mm diameter by approximately 650mm deep (Fig. 2).
- 2.2 Place approximately 200mm of coarse gravel into the hole.
- 2.3 Insert the main standard into the ground socket. Engage the locking collar and lock into position.

Make sure the tabs are closed to prevent concrete entering the locking recess.

- 2.4 Place the ground socket and main standard into the hole.

Push the base of the ground socket into the gravel.

Check level vertically.

The top of the ground socket must sit approximately 6-12mm above ground level.

- 2.5 Support the main standard and concrete into position.

Concrete should be damp enough to 'hold together' when squeezed in your hand.

Settle concrete by pushing a thin stick into the mix several times.

Leave the main standard in the ground socket until the concrete has set.

Keep concrete out of the locking recess in the ground socket.

- 2.6 Allow 24 hours for the concrete to set before final assembly and use of your Rotary Hoist.

Fig. 2

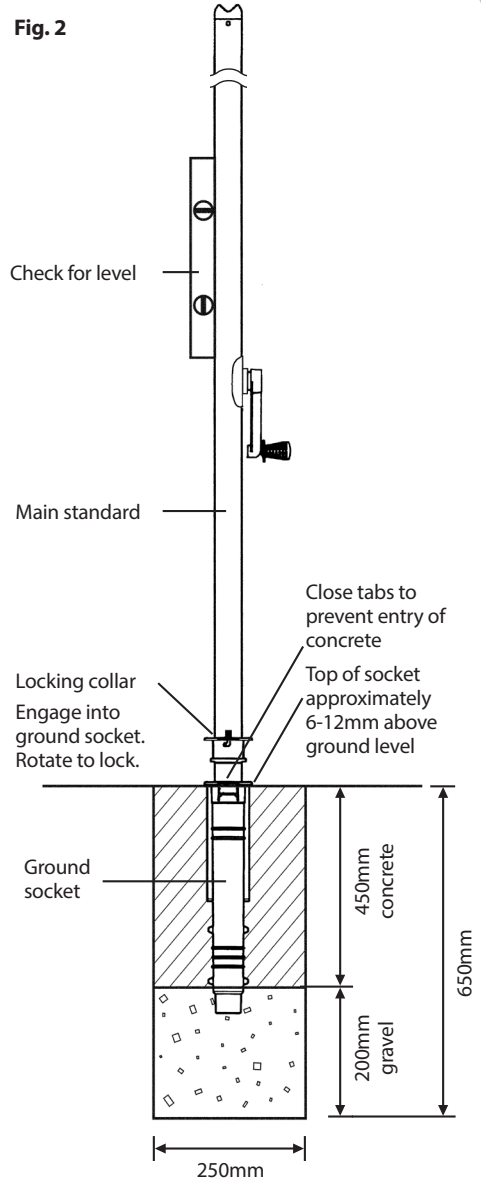

Step 3 – Assemble the Hoist

- 3.1 Place the main standard in the ground socket.
- 3.2 Place the bottom of the head assembly into the top of the main standard and lower it gently until it stops (**Fig. 3**).

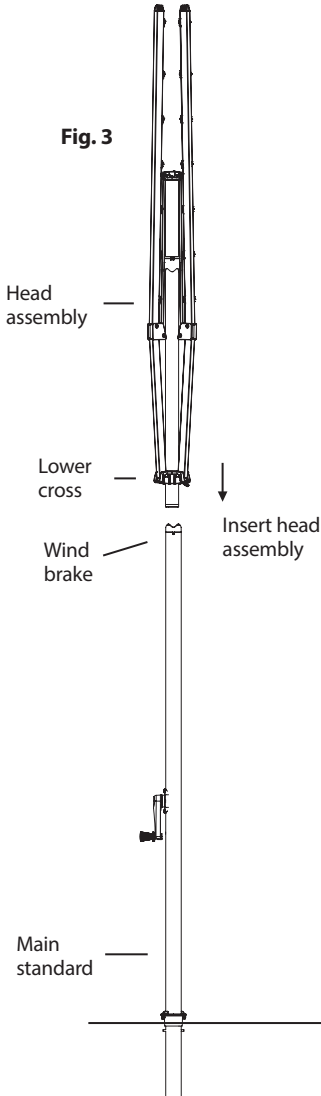

- 3.3 To engage, raise the head assembly by approximately 100mm and lower until a 'click' is heard.
- 3.4 Check the head assembly is locked in position by lifting upwards (it should not move). If the head assembly is not engaged, repeat Step 3.3.

Note: There is a small amount of rotational movement between the wind brake and the lower cross latch.
This is normal.

Note: Once the head is engaged into the main standard it cannot be removed.

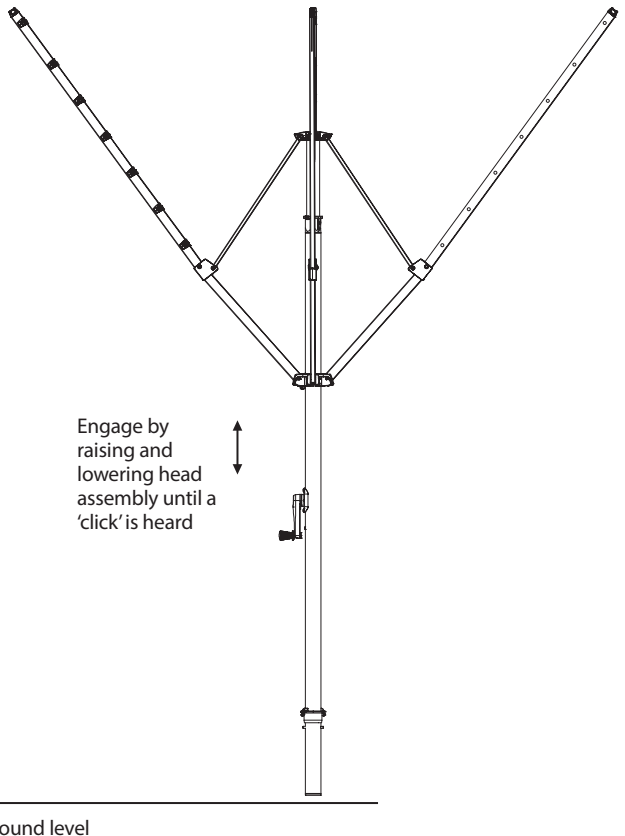

Step 4 – Operating the Hoist

4.1 To adjust the height of your Rotary Hoist, wind the handle and head assembly down and then fit one or more of the plastic spacers in the ground socket.

The suggested operating height is the user's head height +25mm (**Fig. 4**).

Note: The height adjusting winding mechanism has an automatic device to disengage the handle at the maximum and minimum heights.

A slight 'clicking' noise will be heard when this system is operating.

4.2 To open: Undo the line tie-off cord. (**Refer to Step 6**). Make sure the lines are tangle free. Push the lower cross and arms up until the latch engages.

4.3 To fold: Press the latch to release the lower cross. Place your hands on the arms and pull downwards.

4.4 Wrap and fasten the line tie-off cord around the hoist to prevent lines from becoming tangled.

4.5 To remove from the ground socket: Unlock the locking collar by rotating anti-clockwise. Lift the Rotary Hoist from the ground socket and store in a suitable place. Insert the cover into the top of the ground socket.

Fig. 4

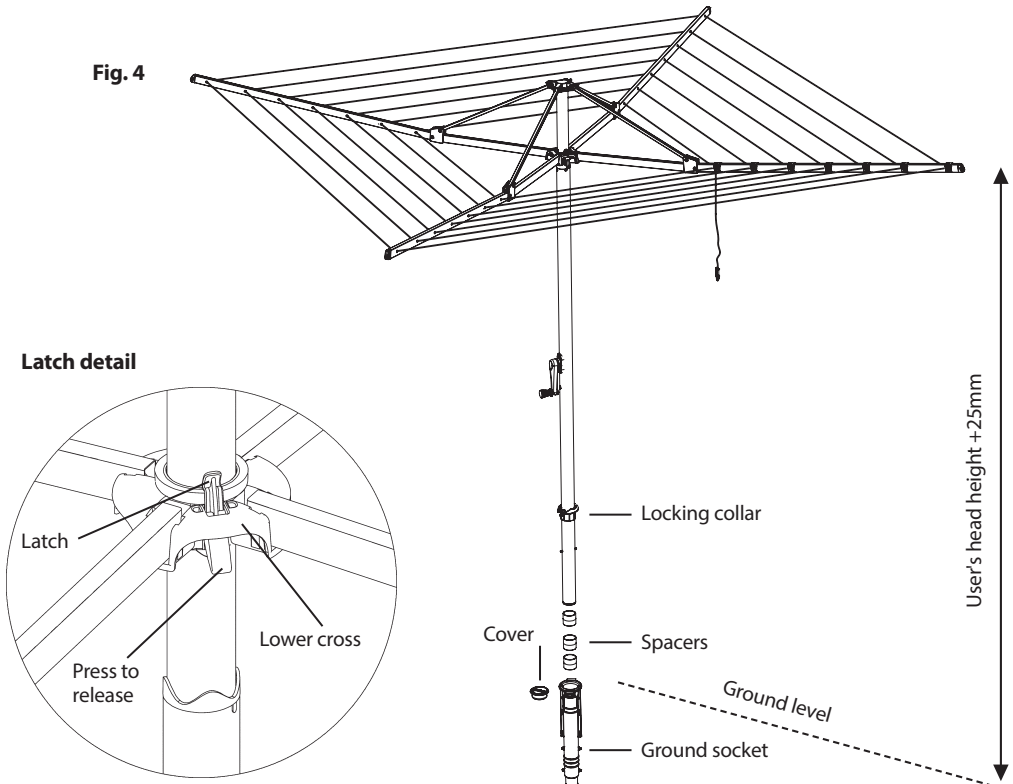

Step 5 – Tensioning the Lines

The lines are pre-tensioned in the factory. No initial tensioning is required.

If over time, the line does need tensioning, the Rotary Hoist **must** be in the open position.

- 5.1 Insert the Rotary Hoist into the ground socket, open up and lock into position (**Fig. 5**).
- 5.2 If the whole clothesline needs to be re-tensioned, start from the outside line and work towards the centre.

If only a single line requires re-tensioning, just re-tension this particular line.

In either case, untie the PVC line from the line tie-off saddle on one side of the arm only. Pull PVC line through one arm at a time until line is taut. Re-tie PVC line around tie-off saddle. Trim off any excess line if required. Push line into the hole in the arm.

Do not over tension the lines.

Fig. 5

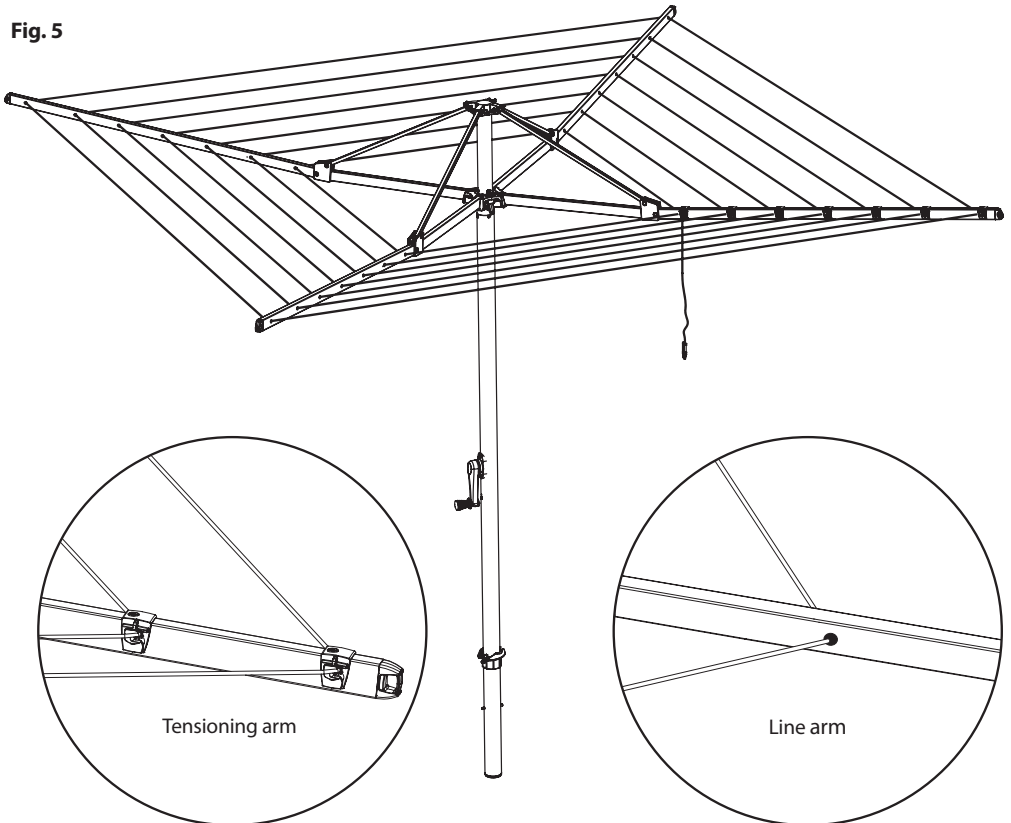

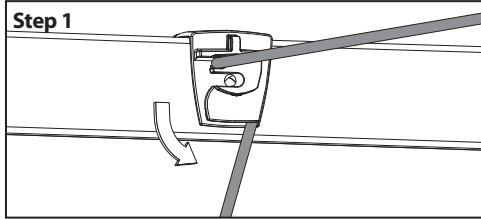
Step 5 (continued)

Pull line out of arm.

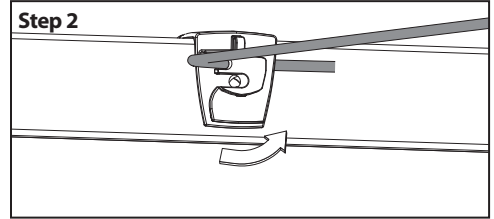

Remove line from under locking lip.

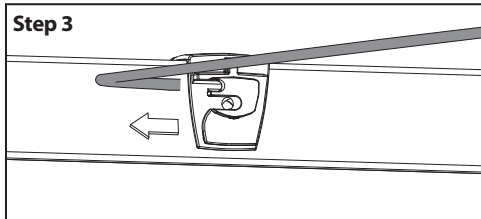

Pull line out from tensioner.

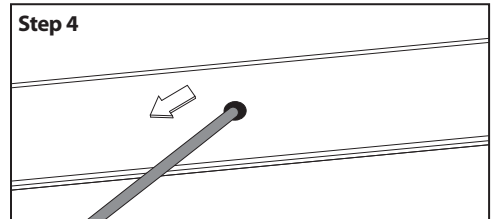

Starting at the furthest arm from the tensioning arm, pull the line tight and move from arm to arm to generate desired line tension.

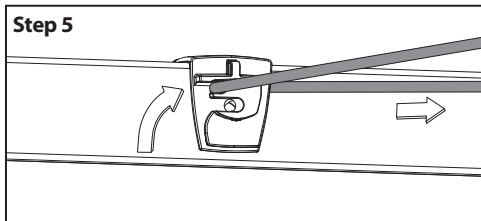

Keeping the tension on the line, feed it back through the tensioner. Pull to retain tension.

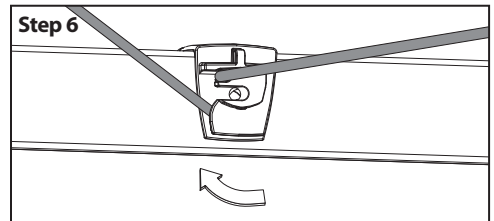

Swing the line back under the tensioner lip to secure. **TIP:** Keep pressure on bottom left edge to stop tension loss.

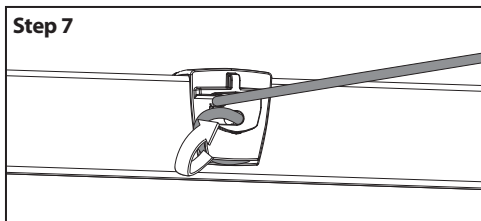

Feed line back into arm through central hole. Cut off excessive line if required prior to putting into arm.

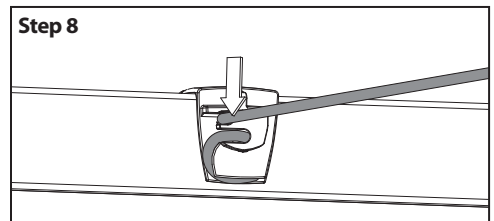

Push line firmly into arm to give a flush result.

Step 6 – Line Tie-Off Cord

IMPORTANT: The extended length of clothesline fitted with a plastic toggle is called the line tie-off cord, and is designed to keep lines neatly together when the Rotary Hoist is not in use.

- 6.1** Never leave the line tie-off cord in an unsecured position (**Fig. 6a**).
- 6.2** When the Rotary Hoist is not in use, fold the arms against the Main Standard and wrap the line tie-off cord around all of the arms, securing the clothesline. You may have to wrap the line tie-off cord around the arms twice (**Fig. 6b**).
- 6.3** When the Rotary Hoist is in use, securely fasten the line tie-off cord out of the way by stretching it between two arms and attaching the hook at the furthest most point from the origin (**Fig. 6c**).

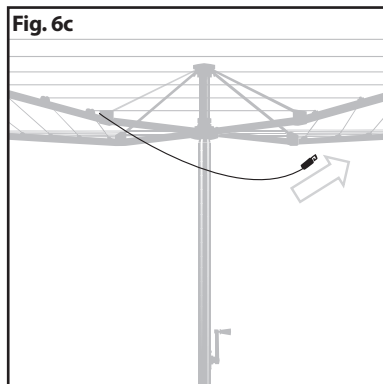
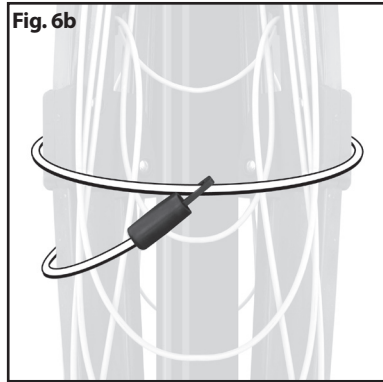
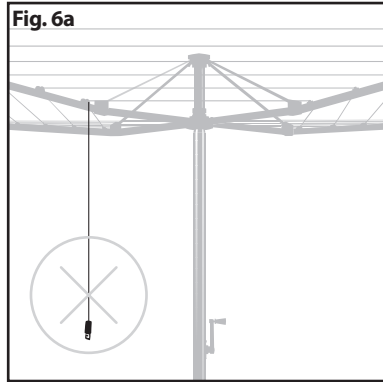

Sun King Handy Hints

One of the benefits of a Rotary Hoist is that it spins naturally in the breeze, allowing the sun to shine on all your clothes and speed up drying time.

Raise your hoist for maximum drying efficiency and to ensure clearance for longer items.

The wind brake assists in the pegging and unpegging of clothes on windy days by restricting the free rotation of the clothesline. It can be engaged by winding the 'head' of the hoist fully down.

Place smaller items of clothing on the lines nearest the centre and work your way outwards for larger items.

When hanging thick or bulky items, you may hang the item over more than one line.

When you do not expect to fill the capacity of your hoist, hang your clothes on the outer lines, this will allow your clothesline to spin more easily.

Care and Maintenance

It is a good idea to occasionally inspect all components and check for wear and tear or damage. If there is any damage, parts should be replaced with original Sun King spares or the Hoist repaired before using again.

The hoist should be periodically wiped clean with a damp cloth and mild detergent.

Your Rotary Hoist can be easily folded and removed from the ground socket to give you extra garden space.

The hoist should be easy to remove from the ground, but if left for a period of many years it may become more difficult. It is recommended the hoist is lifted out of the ground at least every six months.

In addition to all rights and remedies to which you may be entitled under the New Zealand Consumer Guarantees Act (1993) and any other relevant legislation, Holdfast NZ Limited warrants the product to be free from defects in materials or workmanship for 10 years from the date of purchase.

In the event of a claim, you must take the product with proof of purchase and an explanation of the fault to the place of purchase or contact Holdfast NZ Limited and provide your proof of purchase. All costs associated with the return of the good (and other expenses incurred in claiming under this warranty) are your responsibility. We will, at our option, either repair or replace the product if it has a defect in its materials or workmanship.

Holdfast NZ Limited liability under this warranty is subject to Holdfast NZ Limited being satisfied that a defect was caused by defective workmanship or materials and was not caused by or substantially contributed to by other factors including (but not limited to) maintenance or repair, adjustments or modifications of the product in a manner not recommended by the manufacturers or any neglect, misuse or excessive use. For the avoidance of doubt, this warranty does not cover acts of God, earthquake, cyclone, fire, explosion, flood, landslide, lightning, storm, tempest, drought or meteor, war, terrorism, restraint or damage to property by or under the order of any government authority or industrial action.

You are entitled to a replacement or refund for a major failure and for compensation for any other reasonably foreseeable loss or damage. You are also entitled to have the goods repaired or replaced if the goods fail to be of acceptable quality and the failure does not amount to a major failure.

For goods purchased within New Zealand, this warranty is provided by Holdfast NZ Limited ,
14 Avalon Drive, Nawton, Hamilton. Phone 0800 70 10 80.

Holdfast Contacts

HOLDFAST NZ LTD

14 Avalon Drive, SH 1, Nawton 3200

PO Box 4206, Hamilton East 3247

Hamilton, New Zealand

Ph: (07) 847 5540, Fax (07) 847 0324

Free Phone: 0800 70 10 80

Email: sales@holdfast.co.nz

www.holdfast.co.nz

