



Mount Bar 4-line and 6-line

Product Manual



Congratulations

Congratulations on the purchase of your new **Sun King Retracting Clothesline Mount Bar**. It is important that you read these instructions thoroughly before installation and use. In this way you will benefit from all the design features and enjoy safe use of the product. Thank you for choosing Sun King.

Carton contents

Part name	Qty.
Mount bar 4 or 6	1
Product manual	1
Mount bar accessory bag (includes):	1
2 x bolt – socket head M8 x 80	
2 x bolt – socket head M8 x 45	
4 x nyloc nut – M8	
6 x M8 washer	
1 x Hex key	

Please retain this Product Manual. Record the following information for future reference.

Product Number (printed on carton): _____

Date of purchase: _____

Name and location of store: _____



Designed and tested under a Quality System that meets Hills demanding quality specifications.

Made in China

Assembly

- 1.1 Attach the Mount Bar to the post with bolts M8 x 80, nuts and washers. The heads of the bolts should be located flush within the recess.
- 1.2 Attach the cabinet to the Mount Bar using bolts M8 x 45, washers, and nuts. Ensure the washers are fitted **between** the head of bolt and the mount slot in the cabinet. Refer to your Retracting Clothesline owner's manual.

Note: The Retracting Clothesline and post are not included in this Mount Kit.

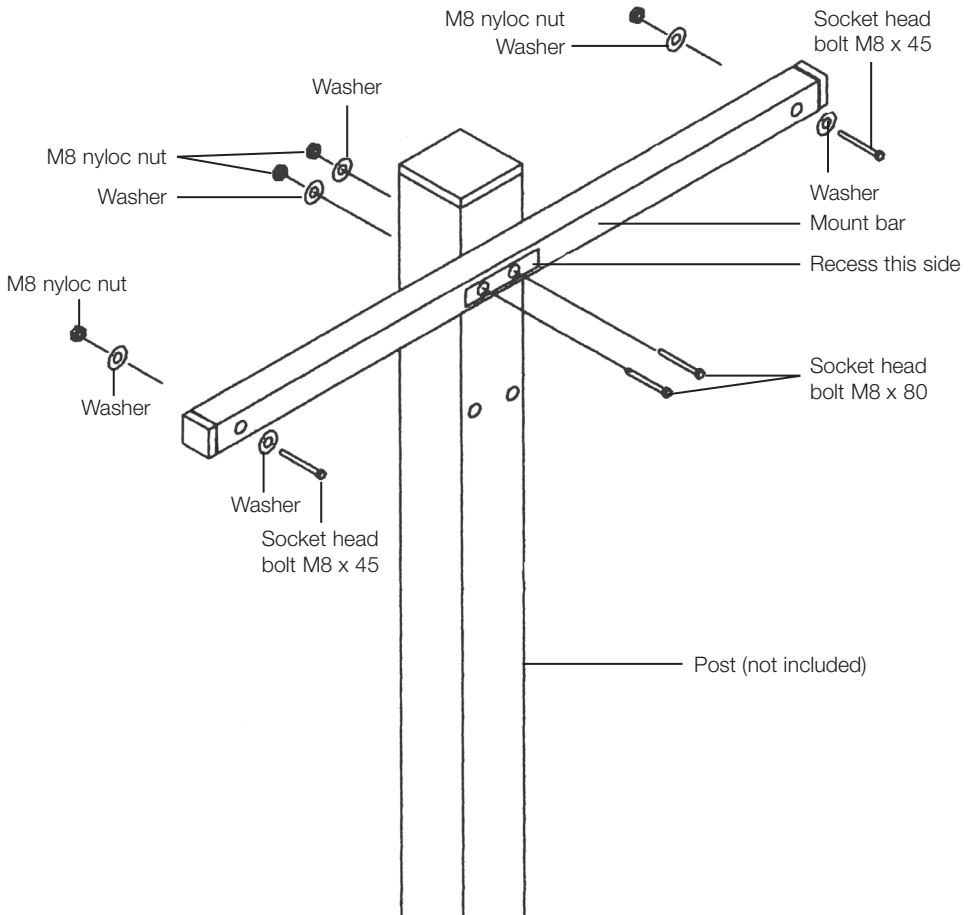

In addition to all rights and remedies to which you may be entitled under the New Zealand Consumer Guarantees Act (1993) and any other relevant legislation, Holdfast NZ Limited warrants the product to be free from defects in materials or workmanship for 10 years from the date of purchase.

In the event of a claim, you must take the product with proof of purchase and an explanation of the fault to the place of purchase or contact Holdfast NZ Limited and provide your proof of purchase. All costs associated with the return of the good (and other expenses incurred in claiming under this warranty) are your responsibility. We will, at our option, either repair or replace the product if it has a defect in its materials or workmanship.

Holdfast NZ Limited liability under this warranty is subject to Holdfast NZ Limited being satisfied that a defect was caused by defective workmanship or materials and was not caused by or substantially contributed to by other factors including (but not limited to) maintenance or repair, adjustments or modifications of the product in a manner not recommended by the manufacturers or any neglect, misuse or excessive use. For the avoidance of doubt, this warranty does not cover acts of God, earthquake, cyclone, fire, explosion, flood, landslide, lightning, storm, tempest, drought or meteor, war, terrorism, restraint or damage to property by or under the order of any government authority or industrial action.

You are entitled to a replacement or refund for a major failure and for compensation for any other reasonably foreseeable loss or damage. You are also entitled to have the goods repaired or replaced if the goods fail to be of acceptable quality and the failure does not amount to a major failure.

For goods purchased within New Zealand, this warranty is provided by Holdfast NZ Limited, 14 Avalon Drive, Nawton, Hamilton. Phone 0800 70 10 80.

Holdfast Contacts

HOLDFAST NZ LTD

14 Avalon Drive, SH 1, Nawton 3200

PO Box 4206, Hamilton East 3247

Hamilton, New Zealand

Ph: (07) 847 5540, Fax (07) 847 0324

Free Phone: 0800 70 10 80

Email: sales@holdfast.co.nz

www.holdfast.co.nz

